



Commissioning Capital Plant

July 2007

The Institution of Professional Engineers New Zealand Incorporated (IPENZ) is the non-aligned professional body for engineering and technology professionals in New Zealand.

Practice Notes offer guidance to practising engineers by exploring issues of importance to the profession and setting out good-practice methodologies. They are written by practitioners and subject to peer review by IPENZ Members. While every care is taken in their preparation, these documents are not offered as formal advice. Any liability arising from their use rests with the practitioner.

Practice Notes are copyright to IPENZ and cannot be reprinted without permission.

ISSN 1176-0907

Introduction

The process and methodology of capital plant commissioning and start-up is often poorly understood and poorly executed by engineers to the detriment of the client's project and business. Plant that is poorly commissioned is usually late and over budget, operates below optimum performance, and can incur substantial penalties for the contractors and client. Poorly-executed commissioning often leads to extensive action under contract law to recover costs from the contractors or engineers.

This *Practice Note* provides engineers who are involved (or will become involved) in the commissioning of capital plant with a plan for accomplishing a good, fast and complete start-up. In addition, it provides an insight into the dynamics of commissioning as they relate to situations and project personalities.

The Meaning of Commissioning

Commissioning has a different meaning for different engineering disciplines and, indeed, project managers and clients. Serious mistakes are often made during both large and small projects because of the differing perceptions of the various players within the project group.

In some projects, where substantial sections of the plant are supplied by overseas vendors, project managers have made the erroneous assumption that commissioning and start-up is included in the vendor supply; at the last minute they find out that the vendor's representative is unable or unwilling to provide commissioning. Large-scale plant integration of multiple vendors can also be a fertile ground for misunderstandings about who is commissioning what and who is responsible for interfacing between packages. Inadequate interface responsibility during commissioning is one of the major reasons for late delivery of plant start-up.

Starting at the project drafting stage, commissioning is a multistage and integrated activity that delivers a started and optimised plant to the client on time. It is a disciplined activity involving careful testing, calibrating and proving of **all** systems, software and networks within the project boundary. This ensures nothing is left to chance, so that when buttons are pushed all logic interlocks are fully proved and operate correctly (including all PLC [programmable logic controller] software), and problems, if they occur, will be design or process failures, not wiring, specification, software, communication, instrumentation or functional errors.

There should be a written commissioning plan that covers the entire project and this plan is normally approved before commissioning starts. The commissioning plan should identify hold points, decision-to-proceed points, and the go-no-go criteria.

Commissioning teams should be comprised of specialist engineers, vendors, electrical instrumentation technicians, electricians, client engineers, maintenance personnel and, lastly but no less important, the production personnel. The chief commissioning engineer can be based in any discipline, but should have several years of large-scale plant experience.

Commissioning requires planning, leadership, teamwork, communication, training and co-operation. This *Practice Note* outlines both the triple-colour pre-testing system and the 100% tested approach, and provides the practising engineer with the information and skills needed for commissioning capital plant.

Drafting and Nomenclature

Obviously, plant drawings and schematics are essential to commissioning, and the commissioning leader should examine them right at the beginning of the project. The designated commissioning engineer should view the drawings standard and nomenclature as the project is scoped. It is very important to get nomenclature right when the drawings are produced. Likewise, it is very important to ensure electrical, instrumentation, piping, vendor plant, mechanical, process plant, hold card and PID (process instrumentation diagram) schematic standards are correct at the beginning of the process.

All systems and equipment must be provided with clear location-oriented nomenclature that is reflected in the schematics. All drawings and schematics should be fully zonal (by floor and "geo-location" within the floor) and reflect the nomenclature. The schematics should flow in a logical manner from utilities to process. The entire drawings set should then follow the process flow.

A full set of drawings, complete with the latest changes, is required for commissioning. This set must be available for multiple photocopying and rebinding into robust plant subsection field environment folders. Subsection breakout of the drawings set is greatly assisted if the drawings subsets follow the plant process flow. Plant labelling for all MCCs (motor control circuits), high-voltage switchgear, control desks, drives, vendor packages, cables, distribution and HVAC (heating, ventilation and air conditioning) systems must be comprehensive and reflect both the nomenclature and the hold card system.

All process piping should have the industry-standard labels for pipe type, internal product and direction of flow. All vendor packages must have the label standard retrofitted for all motor cables, control panels, instrumentation panels and discrete devices. The requirement for these labels to be on the vendor packages may be incorporated into the purchase specification; however, it is often difficult to get overseas vendors to add this level of labelling, let alone use the nomenclature standard. For efficient commissioning, labelling that is consistent with the project nomenclature standard must be added once the packages have arrived.

Many vendor packages have a wholly inadequate drawing standard and a redraw may be required to properly integrate a package into the plant schematics. In some cases, however, a simple interface drawing may be all that is required to bring the vendor's set into the plant drawings set. A complete junction box redraw is required for plant that is designed to be wired using conduit wiring rather than a multicore cable connection, which is the norm. The plant PID should be suitable for wall charting and coloured for the various piping arrangements.

In-factory Package Acceptance Testing

Many vendor-supplied packages include in-factory acceptance testing. The veracity of such testing can be quite variable and sometimes the level of factory testing that can be performed depends on the complexity of the plant. In any case, it is crucial that the assigned commissioning engineer is present at the factory testing and specification verification so that he or she may view the system, its drawings and the testing plan, and witness the actual testing and acceptance.

Witness testing allows the commissioning engineer to visualise how the package will be commissioned and, importantly, when and where in the schedule the package should be commissioned. It also allows the commissioning engineer to find out what additional labelling and drawings will be required.

Factory acceptance is usually applied to more complex elements such as DCSs (distributed control systems) and process units. Unfortunately, such systems cannot be fully tested unless significant levels of simulation software are available and being tested. In some circumstances the commissioning engineer may consider it unnecessary (despite the purchase specifications) to conduct extensive acceptance testing. This is because the amount of testing that can be done on the process unit in isolation from the rest of the process elements is insignificant, and it would be better to wait until the process elements are installed in the process and connected to the other units. This is an example of the judgements commissioning engineers must make during the various stages of the project.

Interface Pre-testing

Interfacing is often the element that causes significant commissioning failure because the project management team assumes that the responsibility for correct interfacing remains with the vendor package supplier. Interfacing problems that will cause significant commissioning delays if not corrected early in the process include:

- a lack of junction boxes for cable interconnections
- discrete components set up for conduit wiring
- poor drawings for interfacing piping, air systems, electrical and instrumentation systems
- incorrect wire or piping colours

After the interfacing systems have been organised they must be pre-tested in a manner that tests and checks the interfacing connections. The devices connected by the interface must also be exercised to confirm their intended function and response.

It cannot be overemphasised how important it is to ensure vendor package interfacing is correct and fully pre-tested, including verification of unit element specifications. Some commissioning engineers on mission-critical plant will go as far as field calibration of instrumentation on vendor-supplied packages. For example, if the element has a flow sensor they will simulate flow, calibrate, measure and prove as part of pre-testing even though the element is part of a pre-tested factory-accepted vendor package. The extent of vendor package

confirmations is a matter of judgement on the part of the experienced commissioning engineer. It also depends on the level and quality of the factory-acceptance testing and the criticality of the element or unit. Some commissioning engineers will perform a 100% commissioning effort on all elements, including vendor supplied packages, while others will stop at vendor package interface and assume the package is present and correct.

Utility Pre-testing

Most capital plant have extensive utilities, such as high-voltage switchgear, motor control centres, gas, air and auxiliary power supplies. For accurate and smooth commissioning of the major plant items, the utilities must be properly pre-tested and commissioned in order.

All high-voltage switchgear must be inspected, checked against specification and all auxiliary circuits pre-tested. Often floor-mounted switchgear is ordered as a bolted-together suite of equipment that is simply placed over the switchroom trenches and bolted down. A commissioning engineer working on the 100% principle will apply a full set of inspections and tests during the utility pre-testing phase, not only to switchgear but also components like air supplies, white water supplies, gas and hydraulics.

For a 400-Volt, 3000-Amp suite of withdrawable switchgear, for example, the commissioning engineer or a member of his or her team will: inspect the suite for level; excite the main breaker current transformers using a test box and make the protection trip; check the busbars and perform torque tests on busbar bolts and clamps; perform a micro-ohmmeter test on **all** busbar joints; bell test all auxiliary circuits; and check all MCCs for thermal sizing and cable connections. Working out from the switchgear, he or she will check the connected motors for specification, bell test the power cable, check cable size and correct phase rotation on each and every connected motor circuit, and then apply hold cards to every starter set.

Again, the level of testing depends on the criticality of the connected plant and the effect of downtime if an MCC starter implodes during the starting of a 150-kilowatt motor with an undersized starter module. For capital plant with a large grouping of motors it is important that the 100% principle is applied to utilities as a huge amount of time can be lost because of relatively simple problems with a universal utility.

Pre-commissioning Including Utilities

Pre-commissioning or “cold yellow testing” uses the prepared commissioning drawings sets. At this stage, all circuits, power cables, instrumentation loops, PLC input and output connections and junction boxes are bell checked without voltage or active auxiliary supplies. All field devices are exercised and manipulated to provide on and off inputs to the PLC or DCS, again without voltage or active auxiliary supplies. The commissioning engineers work in teams with radio communication using different channels for each team. Team members stationed at each node point go through all the system connections and devices one by one in order of the commissioning drawings set. This is when well laid-out drawings and plant really start to pay off for the commissioning engineer.

As each device, circuit, cable or core connection is bell checked or exercised, the relevant circuit in the drawing is coloured with a yellow highlighter (see Figure 1). All data and specifications for devices and motors are also “yellowed off”. During commissioning meetings it is therefore possible to see exactly where the team is up to at a glance by checking the colour of the drawings set. Required changes that are identified as the team is checking are marked in red and noted on the front of the commissioning drawings set. These notes and changes are then transcribed to the master commissioning set at a later time. Once the entire drawings set is yellow the first stage of commissioning is complete and the plan is 100% cold checked. The commissioning team can then move on to the next phase.

In some cases, of course, it is possible to do pre-commissioning and commissioning in parallel; however, great care has to be taken with common utilities. The sections that are still in the yellow phase must be isolated from the areas that are going through the commissioning or “green” phase. Most experienced commissioning engineers prefer to fully complete the yellow phase before advancing to the green phase.

Commissioning

Commissioning or “hot green testing” involves bringing on the high-voltage switchgear, livening the power transformers, switching on the MCC circuit breakers, livening the MCCs, and livening all auxiliary and power supplies for instrumentation control panels and the like. All of these devices have been through the yellow pre-commissioning phase and should come on without any problems. When you liven a distribution panel on the third floor, after 100% yellow pre-commissioning checking of a paper machine, you can be certain that the cable is checked, the right box will be livened and the protection will work.

At this time all starter modules and power supply rails should be hold carded. For capital plant commissioning there must be an extensive, bullet-proof hold card system. It is important to use the industry standard system if possible; however, many hold card systems are designed for use during normal operations and maintenance and may not be suitable for commissioning. Instead, it may be advisable to use a commissioning hold

card rather than a “standard” one. A commissioning hold card will have sections for mechanical and process clearance. Normally the commissioning electrical engineer removes the hold card and starts the motors; to do this he or she must have mechanical and process clearance. Some commissioning protocols will specify these clearances on a list. It is more efficient to provide hold cards with spaces for clearance signatures, or to use coloured stamps.

At this phase of commissioning all the circuits are powered up and flick tested again while the switched PLC inputs and driven outputs are observed. For example, if there is a limit switch input to a PLC then the input card PLC is powered up and the limit switch is exercised so that the powered input can be seen.

Note that at this time the PLC CPU is off and the software or ladder logic is null. If the connected device is a solenoid, it is exercised by powering up the output card and touching a live connection onto the output. Once this is done, the circuit drawing that is currently yellow is **over-coloured** in green. (Yes, the same circuit drawing set is used, see Figure 2.) This means that this circuit has been tested twice – once when cold and once when hot – and thus the circuit device is now said to be “commissioned”. The drawings set progressively changes from all yellow to all green as all circuits and connected devices are hot tested in this manner. When the entire drawings set is green then it can be said that the project is “commissioned”.

Figure 1: Schematic showing yellow phase.

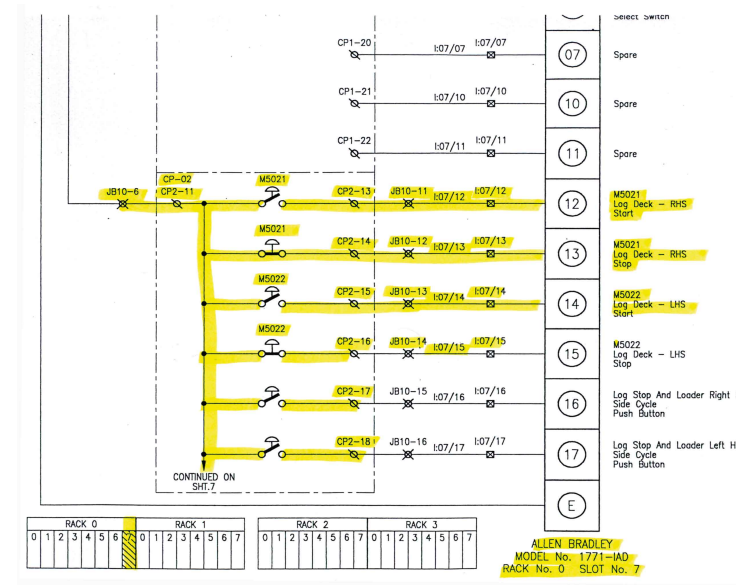

Process Software Commissioning

This phase of commissioning, known as “pink testing”, involves proving the software and ladder logic. All inputs and outputs of all PLCs and DCSs are now fully tested and operational, and the ladder logic is now brought on in sequence. Again, the field devices are exercised so that they bring up hot inputs. With the PLC CPU in the run position, the ladder or sequence logic is scanned for correct operation, interlocks are observed and operated, and outputs are exercised by the software.

This is now the third time the circuits, devices, functional elements and motor starters have been tested. At each step the commissioning engineer must observe which outputs are being exercised and ensure that the process itself does not operate.

Sections of the ladder logic must be locked off so that an errant logic step doesn't complete and interlock further down the sequence. As each rung in the ladder is worked and its interlocks and stepwise logic is checked, the appropriate section in the software printout is coloured with a pink highlighter (see Figure 3).

Sometimes the commissioning systems integrator will use a simulation software package to complete the logic testing during this phase. As long as the external elements are fully exercised then this is acceptable. If the software is a functional block protocol then each block is checked in its totality and coloured accordingly.

During this phase it may be necessary to insert “frigs” to bridge an errant device or where a piece of plant is missing and an interlock is not available. Frigs are usually red pieces of jumper lead with a long, waving red tag attached so it can clearly be seen that there is a frig in the system.

At each commissioning meeting it will be possible to see to what extent commissioning is “in the pink”. Start-up usually occurs when the 80% “in the pink” mark is passed. Instrumentation is handled in much the same way. All loops have been wire tested,

4–20mA loops have been calibrated, and now the functional block that drives the instrumentation inputs and outputs either from the PLCs or DCSs is exercised. At no stage, however, has any process material or liquid been introduced. The entire capital plant has now been triple checked and tested with all computers, PLC, MCCs and field system elements and vendor packages hot and ready to run. Now the plant is ready for the process commissioning phase and the entire team should be advised of this.

During the final phases of the commissioning or “pink” step, members of the plant operating staff should join the commissioning team. This is essential for large-scale capital plant. If you are commissioning a large thermal power station or a large newsprint paper machine then you need the power station operator or the paper maker with you during the next phase.

Process Commissioning

The process commissioning or “purple” phase is concerned with commissioning the actual process the plant will be carrying out. Raw materials are introduced, water, gas or other process fluids fill the tank farm, and the process is progressively “turned”.

By this stage, the plant has been tested three times, the logic has been completely tested, all interlocks have been successfully negotiated and worked through, faulty logic has been fixed or replaced, and all frigs have been removed.

Generally there is a change of personnel at this phase. The process chemist may take over or the operator may take over the kitchen and the commissioning engineer takes a step back, behaving as the backup and advisor. Sometimes, however, the process commissioning engineer is a member of the main commissioning team and merely assumes the lead role as the project gets to the end of the pink phase.

As each section of the plant is brought up to pressure or

Figure 2: Schematic showing green marking over yellow marking.

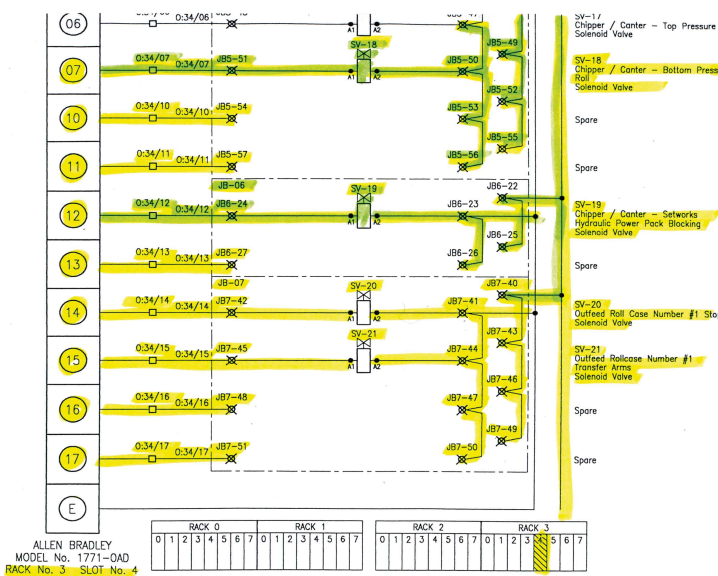
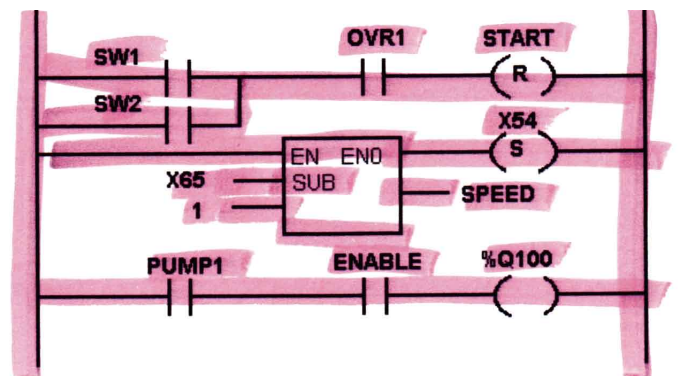

Figure 3: PLC ladder logic marked in pink as sections are commissioned.



temperature, or the kitchen is run, the PID is marked with a purple highlighter. It is usual to commission the process in stages and in strict sequence. Each of the vendor packages is brought on stream in its own right and any process with which it interfaces is run. During this phase the entire commissioning team is equipped with radios and on standby throughout the plant, ready to assist at the PLC or DCS if there are problems. Generally, if the 100% approach has been taken and the three-step pre-testing has occurred, any problems will be with design not systems performance.

It is essential that the commissioning team and its chief engineer are present during the process commissioning phase even if the operating staff have taken full control of the process. The operating staff will have no knowledge of the commissioning procedures that have occurred and will be in no position to provide cogent fault analysis when something does not function. At this time a completed commissioning report is prepared so baselines and “as-set” data are documented.

Start-up

Start-up occurs as an output of the process commissioning phase. Once each section of the plant is process commissioned and the entire PID is purple, the operating staff can go for a complete run. This is where the plant is run according to its production design.

Much of the commissioning team would have stood down or gone home at this point but it is essential that the commissioning engineer remains. During this phase the commissioning engineer must be available for any problems that require fault analysis. The commissioning engineer can also bring his or her journal up to date, write the commissioning reports, and order the “hit list” for handover to the plant management.

The commissioning engineer must do a formal handover at some point in the process commissioning phase or the start-up phase. Generally this occurs when the commissioning process is “taken over” by the operating staff or the chemical plant engineer. Before any capital plant is operated an experienced plant engineer should walk the plant and ensure that no “space junk” has been left in the equipment.

Optimisation

After start-up, and sometimes much later, optimisation is carried out. Often this occurs long after the commissioning engineer has left the site and is usually performed by specialist engineers and the operating staff. If the plant is relatively small, such as a large air conditioning plant, the commissioning engineer may be responsible for balancing the systems and optimising the energy consumption. It will be necessary to have the vendor available during this process. For large plant, optimising can take months and a completely new team is required from the one that commissioned the plant.

Key Points for the Commissioning Engineer

Manage your project manager

Some project managers can be a significant block to commissioning success, especially those who are not engineers or who are poor engineers. Even more problematic are project managers with a propensity to ignore expert advice because it does not fit the project criteria. Be professional and maintain your position, but at the same time ask the project manager to assist you to enable a plan that will reduce commissioning time to fit the schedule without compromising plant safety.

Avoid “last cab off the rank” syndrome

Often vendors or other commissioning engineers arrive late in the project and question why the process is not further advanced. Walk them through the project, carefully explaining that his or her section is late because it is essential that it is right and it has taken some time to get to that point. Ask if he or she needs additional resources and show how your team is working with other vendors to assist the commissioning process. Give them confidence that your team is a group of professionals that will move quickly, efficiently and accurately when the time comes to integrate his or her vendor package.

Schedule site time and attendance

Do not allow all decisions to reach you. Allow subsections within the commissioning team to handle negotiations and decisions when appropriate, but ensure that they approach you when changes are mooted or resource problems occur. Resource issues are the biggest problem during commissioning but they are usually the easiest to resolve. Personal time is important to avoid the “commissioning stress blues”.

Identify the responsible person

You must have a responsible person for each and every major area so that sub-decisions can be made and someone can be accountable at commissioning meetings. If a subcontractor within a zone is not keeping up then this should be reported to the commissioning manager during the commissioning meeting, and the team should then propose methods for helping the subcontractor meet the deadlines.

Work for the client

During pre-commissioning, nothing and nobody should compromise the start-up, including the client’s own managers. As commissioning and start-up manager you must have complete control of all sectors and that includes the client’s own management, production and maintenance. At the end of the day, all of your actions are intended to protect the project, its completion date and the client.

Choose your team carefully

All commissioning teams should include vendor representatives, electrical instrumentation technicians, electricians, client engineers, maintenance personnel and production personnel.

Maximise commissioning meetings

Commissioning meetings should be short and follow a pre-determined pattern. They must not be hijacked by the latest drama or disaster, or become a finger-pointing battleground.

Contractual niceties should not compromise start-up but instead be sorted out later. When the team leaves the meeting all problems should be resolved and any team member who is lagging behind should have received assistance.

Shorter “prayer” meetings should be held every day with major meetings every second or third day depending on need. Prayer meetings should have a set format and not indulge in matters that are normally reserved for the main meeting. Negotiations for access or resources are discussed at prayer meetings.

Eliminate finger pointing

Blaming is damaging and can potentially compromise the start-up. It should be eliminated from the project culture at the beginning of the job by the commissioning or start-up manager.

Don't change design and constructional elements during the last phase

Required changes to design and constructional elements should be added to a “hit list” for later action.

Think yellow, green and pink

Follow the triple-colour pre-testing system and you will always deliver a successfully commissioned, on-time project.

Further Reading

Dowling, E C and Marsden, J I 2004, *Improving and Optimizing Operations: Things That Actually Work!*, Society for Mining, Metallurgy and Exploration Inc., Littleton.

Horsley, D 1998, *Process Plant Commissioning*, The Institution of Chemical Engineers, London.

Kiameh, P 2003, *Electrical Equipment Handbook*, McGraw-Hill, New York.

McDowall, R L in press, *Tuning for Minimum Smoke – Capital Plant Commissioning*.

Acknowledgements

This *Practice Note* was developed by Dr Ir. Ron McDowall.



For more information, contact:



National Office
PO Box 12 241
Wellington 6144
New Zealand

T 64 4 473 9444
F 64 4 474 8933
E ipenz@ipenz.org.nz
W www.ipenz.org.nz